

Accessories for Piezoelectric and ISOTRON® Accelerometers

ENDEVCO MODEL	USED WITH (Examples)	THD SIZE, ACCEL SIDE	ACCEL MOUNTING TORQUE	THD SIZE, MOUNTING SIDE	TRIAxIAL	MATERIAL	WEIGHT GRAMS	ISOLATED	MAX. TEMP	DRWG NO.
2950	Various Accels. with 10-32 Thd.	10-32 X 3	18 lb-in	4-40 x 3	YES	ALUMINUM	20.5	YES	+177°C	1
2950M3	2221F, 7221, 7251	6-32	10 lb-in	4-40 x 3	YES	ALUMINUM	20.5	YES	+177°C	2
2961	2222C	Adhesive	N/A	10-32	YES	MAGNESIUM	3.4	NO	N/A	3
2967A	7255A, 2255B	1/4-28	24 lb-in	10-32 x 2	YES	BERYLLIUM	5.1	NO	N/A	4
2950M16	25A	Adhesive	N/A	Adhesive	YES	ALUMINUM	0.6	YES	+125°C	5
2980B	Various Accels. with 10-32 Thd.	10-32	18 lb-in	10-32	NO	STAINLESS	4	YES	+260°C	6
2980M4	Various Accels. with 10-32 Thd.	10-32	18 lb-in	10-32	NO	STAINLESS	4.5	YES	+260°C	7
2980M9	Various Lightweight Accels. with 10-31 Thd.	10-32	18 lb-in	10-32	NO	ALUMINUM	4.3	YES	+177°C	8
2981-1	Various Accels. with 10-32 Thd.	10-32	18 lb-in	10-32	NO	STAINLESS	1.2	NO	N/A	9
2981-3	Various Accels. with 10-32 Thd.	10-32	18 lb-in	10-32	NO	STAINLESS	1	NO	N/A	10
2981-4	Various Accels. with 10-32 Thd.	10-32	18 lb-in	5 mm	NO	STAINLESS	1	NO	N/A	10
2981-11	Various Accels. with 10-32 Thd.	10-32	18 lb-in	10-32	NO	STAINLESS	0.6	NO	N/A	11
2984-2	2225M5A	1/4-28	24 lb-in	1/4-28	NO	STAINLESS	2	NO	N/A	12
2984M3	2221F, 7221, 7251	6-32	10 lb-in	10-32	NO	STAINLESS	6.5	NO	N/A	13
2985	Various Accels. with 10-32 Thd.	10-32	18 lb-in	10-32	NO	STAINLESS	7.5	YES	+400°C	14
2986B	Various Accels. with 10-32 Thd.	10-32	18 lb-in	10-32	NO	STAINLESS	7.5	YES	+260°C	15
2987	2221F, 7221, 7251	6-32	10 lb-in	Adhesive	NO	STAINLESS	4.4	NO	N/A	16
2988	Various Accels. with 10-32 Thd.	10-32	N/A	Adhesive	NO	ALUMINUM	1.3	YES	+177°C	17
2988M7	7754-1000	10-32	18 lb-in	Magnet	NO	STAINLESS	20	YES	+125°C	18
15071	2270	1/4-28	24 lb-in	10-32	NO	STAINLESS	1.5	NO	N/A	19
2984-1	Various Accels. with 10-32 Thd.	10-32	24 lb-in	1/4-28	NO	STAINLESS	1.5	NO	N/A	20

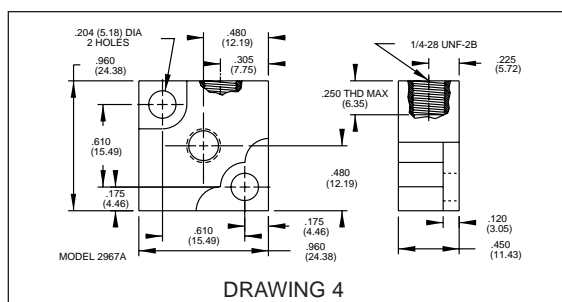

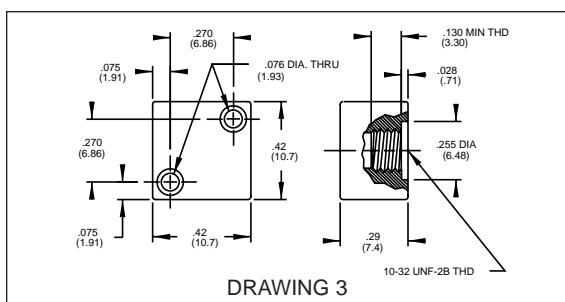
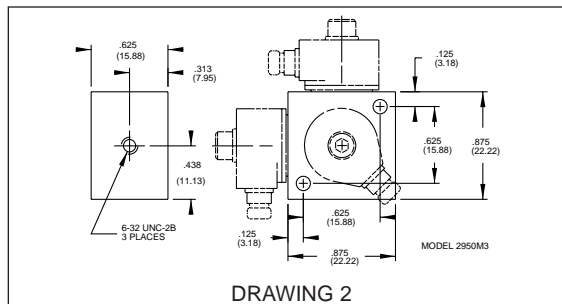
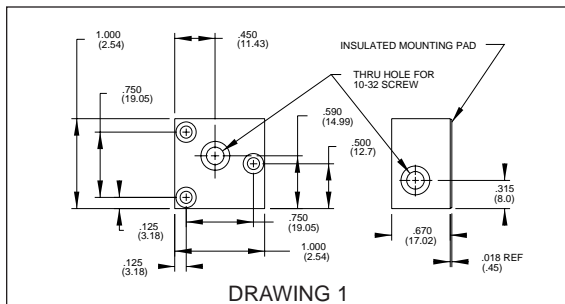
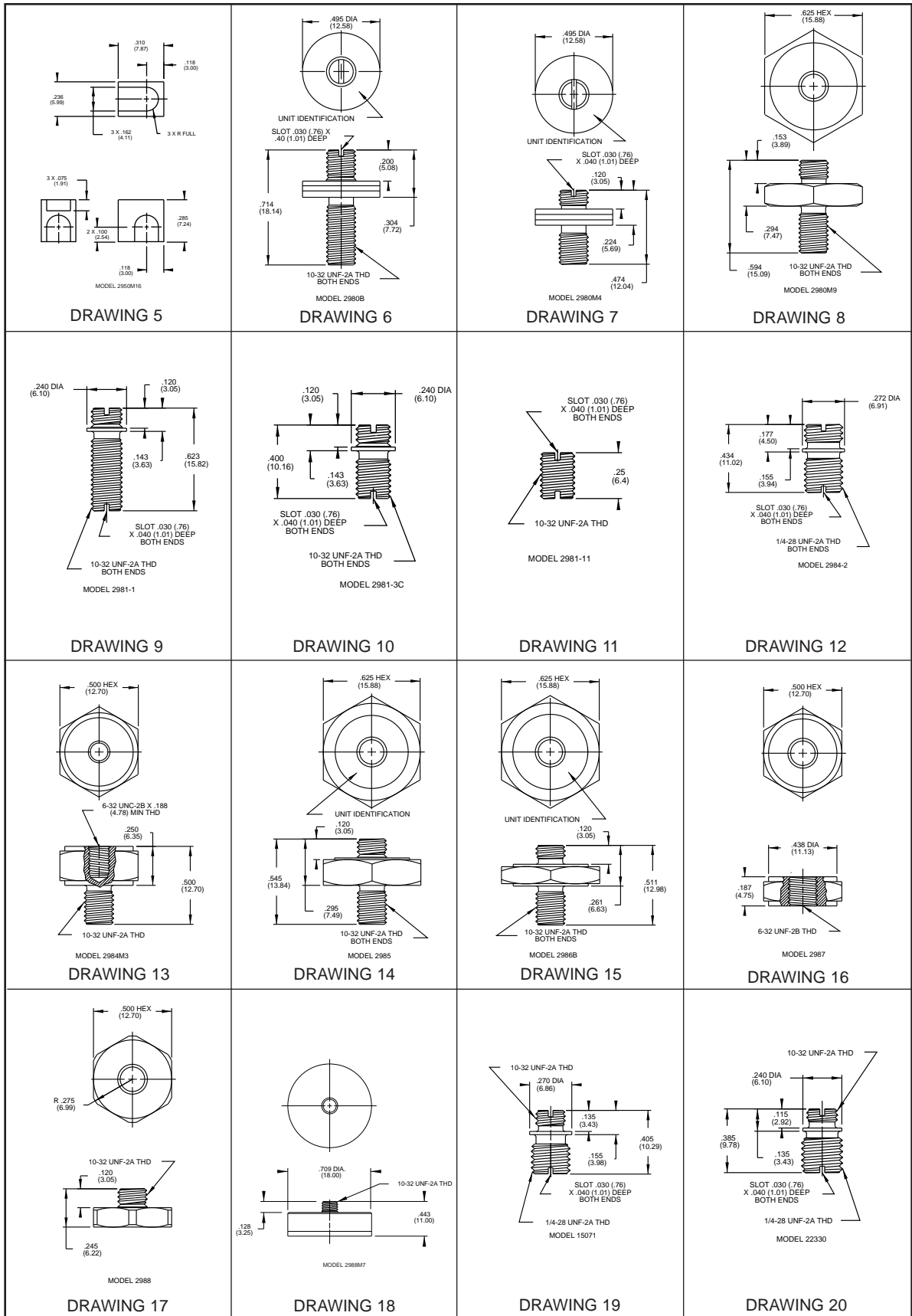

Continued product improvement necessitates that Endevo reserve the right to modify these specifications without notice. Endevo maintains a program of constant surveillance over all products to ensure a high level of reliability. This program includes attention to reliability factors during product design, the support of stringent Quality Control requirements, and compulsory corrective action procedures. These measures, together with conservative specifications have made the name Endevo synonymous with reliability.